

Inch series PILLOBALL Rod Ends **Insert Type/With Male Thread**

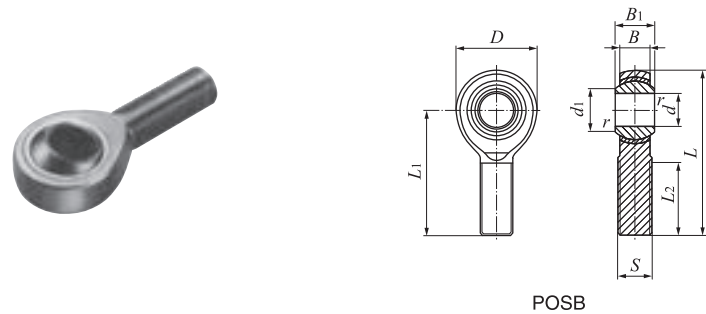

POSB

Identification number	Mass (Ref.) g	Boundary dimensions mm(inch)											Dynamic load capacity C_d N	Static load capacity C_s N
		d	Thread S class 3A	D	B	B_1	d_1	L	L_1	L_2	$r_s^{(1)}$ min	Ball dia. mm (inch)		
POSB 2	5.4	3.175 (.1250)	-32UNC (.1380)	11.91 (.469)	4.75 (.187)	6.35 (.250)	4.75 (.187)	29.77 (1.172)	23.80 (.937)	12.70 (.500)	0.3 (.012)	7.938 ($\frac{5}{16}$)	1 850	2 160
POSB 2.5	9.1	3.967 (.1562)	-32UNC (.1640)	14.27 (.562)	5.56 (.219)	7.14 (.281)	6.32 (.249)	35.71 (1.406)	28.58 (1.125)	15.88 (.625)	0.3 (.012)	9.525 ($\frac{3}{8}$)	2 600	3 370
POSB 3	14	4.826 (.1900)	-32UNF (.1900)	15.88 (.625)	6.35 (.250)	7.92 (.312)	7.77 (.306)	39.70 (1.563)	31.75 (1.250)	19.05 (.750)	0.3 (.012)	11.112 ($\frac{7}{16}$)	3 460	4 850
POSB 4	23	6.350 (.2500)	-28UNF (.2500)	19.05 (.750)	7.14 (.281)	9.53 (.375)	9.02 (.355)	49.20 (1.937)	39.67 (1.562)	25.40 (1.000)	0.5 (.020)	13.097 ($\frac{33}{64}$)	4 590	8 870
POSB 5	36	7.938 (.3125)	-24UNF (.3125)	22.23 (.875)	8.74 (.344)	11.10 (.437)	11.35 (.447)	58.72 (2.312)	47.63 (1.875)	31.75 (1.250)	0.5 (.020)	15.875 ($\frac{5}{8}$)	6 800	14 200
POSB 6	54	9.525 (.3750)	-24UNF (.3750)	25.40 (1.000)	10.31 (.406)	12.70 (.500)	13.13 (.517)	61.93 (2.438)	49.23 (1.938)	31.75 (1.250)	0.5 (.020)	18.256 ($\frac{23}{32}$)	9 230	21 600
POSB 7	77	11.112 (.4375)	-20UNF (.4375)	28.58 (1.125)	11.10 (.437)	14.27 (.562)	14.88 (.586)	68.28 (2.688)	53.98 (2.125)	34.93 (1.375)	0.5 (.020)	20.638 ($\frac{13}{16}$)	11 200	26 100
POSB 8	122	12.700 (.5000)	-20UNF (.5000)	33.32 (1.312)	12.70 (.500)	15.88 (.625)	17.73 (.698)	78.59 (3.094)	61.93 (2.438)	38.10 (1.500)	0.5 (.020)	23.812 ($\frac{15}{16}$)	14 800	36 200
POSB 10	186	15.875 (.6250)	-18UNF (.6250)	38.10 (1.500)	14.27 (.562)	19.05 (.750)	21.31 (.839)	85.73 (3.375)	66.68 (2.625)	41.28 (1.625)	0.5 (.020)	28.575 ($1\frac{1}{8}$)	20 000	39 300
POSB 12	295	19.050 (.7500)	-16UNF (.7500)	44.45 (1.750)	17.45 (.687)	22.23 (.875)	24.84 (.978)	95.25 (3.750)	73.03 (2.875)	44.45 (1.750)	0.5 (.020)	33.338 ($1\frac{3}{16}$)	28 500	55 000
POSB 16	1 129	25.400 (1.0000)	-12UNF (1.2500)	69.85 (2.750)	25.40 (1.000)	34.93 (1.375)	32.23 (1.269)	139.70 (5.500)	104.78 (4.125)	53.98 (2.125)	0.5 (.020)	47.625 ($1\frac{7}{8}$)	59 300	112 000

Note⁽¹⁾ r_s min stands for minimum allowable value of chamfer r .
 Remark No grease is prepacked. Perform proper lubrication.

Lubrication Type PILLOBALL Rod Ends **Die-cast Type/With Female Thread**

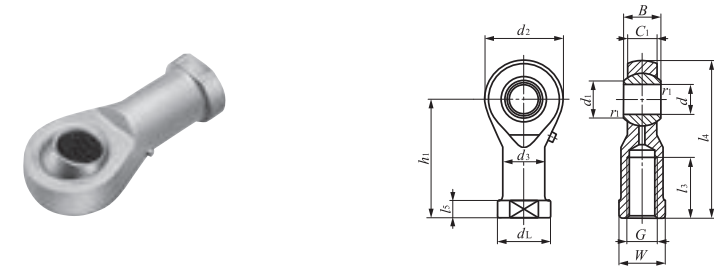

PHSA

Identification number	Mass (Ref.) g	Boundary dimensions mm																Ball dia. mm (inch)	Static load capacity C_s N
		d	Thread G	d_2	C_1	B	d_1	l_4	h_1	l_3	l_5	W	d_3	d_L	$r_{1s}^{(1)}$ min				
PHSA 5	17	5	M 5×0.8	17	6	8	7.7	35.5	27	16	4	9	9	11	0.2	11.112 ($\frac{7}{16}$)	5 470		
PHSA 6	25	6	M 6×1	19.5	6.75	9	9	39.7	30	16	5	11	10	13	0.2	12.700 ($\frac{1}{2}$)	6 760		
PHSA 8	45	8	M 8×1.25	24	9	12	10.4	48	36	19	5	14	12.5	16	0.2	15.875 ($\frac{5}{8}$)	10 200		
PHSA 10	70	10	M10×1.5	28	10.5	14	12.9	57	43	23	6.5	17	15	19	0.2	19.050 ($\frac{3}{4}$)	13 100		
PHSA 12	105	12	M12×1.75	32	12	16	15.4	66	50	27	6.5	19	17.5	22	0.2	22.225 ($\frac{7}{8}$)	16 400		
PHSA 14	155	14	M14×2	36	13.5	19	16.9	75	57	30	8	22	20	25	0.3	25.400 (1)	20 000		
PHSA 16	190	16	M16×2	40	15	21	19.4	84	64	36	8	22	22	27	0.3	28.575 ($1\frac{1}{8}$)	23 900		
PHSA 18	290	18	M18×1.5	45	16.5	23	21.9	93.5	71	40	10	27	25	31	0.3	31.750 ($1\frac{1}{4}$)	28 800		
PHSA 20	400	20	M20×1.5	49	18	25	24.4	101.5	77	43	10	30	27.5	34	0.3	34.925 ($1\frac{3}{8}$)	33 400		
PHSA 22	500	22	M22×1.5	54	20	28	25.8	111	84	47	12	32	30	37	0.3	38.100 ($1\frac{1}{2}$)	40 400		

Note⁽¹⁾ Minimum allowable value of chamfer dimension r_1

Remarks1. A grease nipple is provided on the body.
 2. No grease is prepacked. Perform proper lubrication.
 3. When a metric fine thread specification for inner ring bore deameter d of 8 mm to 14 mm is required, please contact IKO.